

LH DQ 16 KBG 4.8 W STTZN/3 EBS 15.03.47 (419 750)

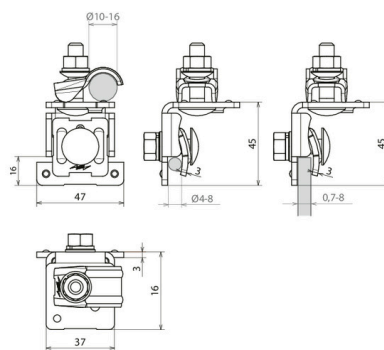

Figure without obligation



Angle bracket for short-circuit wire on stone gabions and steel grid fences.

Type	LH DQ 16 KBG 4.8 W STTZN/3 EBS 15.03.47
Part No.	419 750
Clamp material	HDG steel
Bar clamping range	4-8 mm
Clamping range Rd	10-16 mm
Screw	⬆ M8 x 25 mm, ⬆ M8 x 35 mm
Material of screw / nut	StSt
Material thickness	3 mm
Design with	Spring washer and spherical washer
DB drawing No.	3 EBS 15.03.47
Standard	Ril 997.0204/0205
Weight	162 g
Customs tariff number (Comb. Nomenclature EU)	85389099
GTIN	4013364486898
PU	50 pc(s)

We reserve the right to introduce changes in performance, configuration and technology, dimensions, weights and materials in the course of technical progress. The figures are shown without obligation.